



**CLADMATE**  
Facade Systems

**CMS21**

Double Skin Terracotta  
Cladding Support System

## BRACKETS

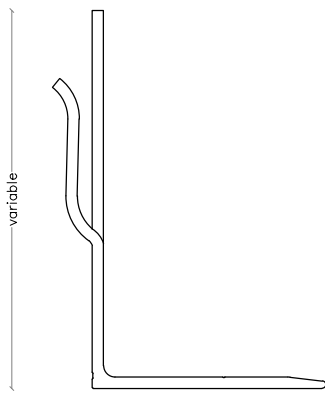

Fortis Helping Hand Bracket

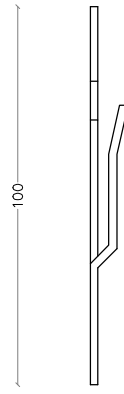

Extension Piece

Description	Code	
	Double	Single
300mm Fortis Bracket	CMF-DB300-6.5/11	CMF-SB80-UN
270mm Fortis Bracket	CMF-DB270-6.5/11	CMF-SB80-UN
240mm Fortis Bracket	CMF-DB240-6.5/11	CMF-SB80-UN
220mm Fortis Bracket	CMF-DB220-6.5/11	CMF-SB80-UN
200mm Fortis Bracket	CMF-DB200-6.5/11	CMF-SB80-UN
180mm Fortis Bracket	CMF-DB180-6.5/11	CMF-SB80-UN
160mm Fortis Bracket	CMF-DB160-6.5/11	CMF-SB80-UN
140mm Fortis Bracket	CMF-DB140-6.5/11	CMF-SB80-UN
120mm Fortis Bracket	CMF-DB120-6.5/11	CMF-SB80-UN
100mm Fortis Bracket	CMF-DB100-6.5/11	CMF-SB80-UN
80mm Fortis Bracket	CMF-DB80-6.5/11	CMF-SB80-UN
60mm Fortis Bracket	CMF-DB60-6.5/11	CMF-SB60-UN
40mm Fortis Bracket	CMF-DB40-6.5/11	CMF-SB80-UN
Extension Bracket	CMF-DBEX	CMF-SBEX

## SYSTEM PROFILES

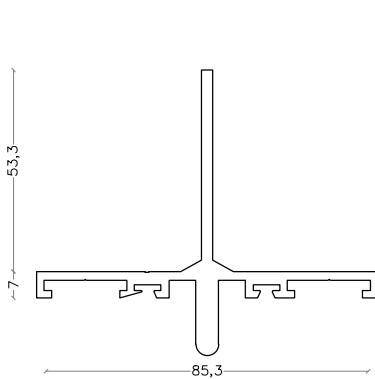

Channel T Profile

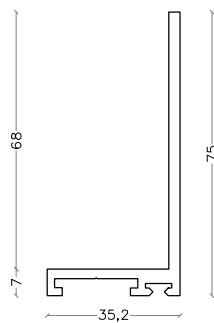

Channel L Profile

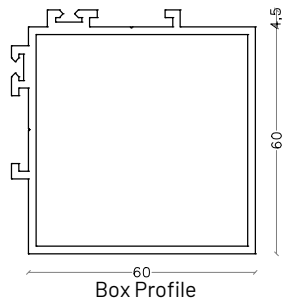

Box Profile

Description	Code
Channel T Profile	VTC-01-85-3000
Channel L Profile	VLC-01-35-3000
Box Profile	BCP-01-60-3000

## CORNER PROFILES

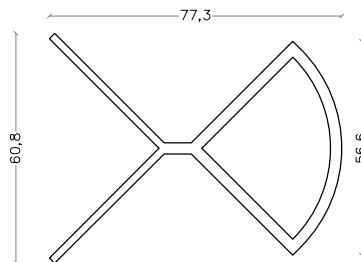

Closed Corner Profile

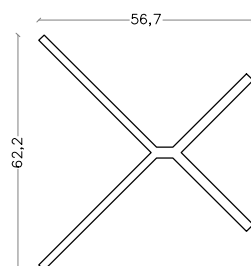

Open Corner Profile

Description	Code
Closed Corner Profile	VCC-P01-3000
Open Corner Profile	VOC-P01-3000

## CLIPS

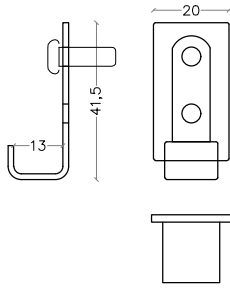

Terra Cotta End Clip

Description	Code
Terra Cotta End Clip	VCC-P01-3000

## FIXINGS

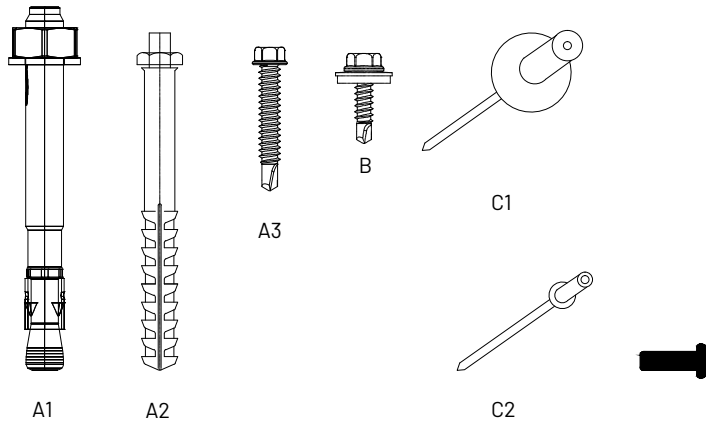

Description	Code
A1 Masonry Primary Anchor Bolt Fixing	BA-V-10/10
A2 Masonry Primary Fixing	SDF-KB-10H-80E
A3 Primary Fixing	JT3-3-6.3-50-S16
B Bracket to Rail Fixing	JT4 4 4.8X19 S14
C1 4,8x25 Rivet	TP01-4.8
C2 4x10 Rivet	TP01-4
D1 Pin	

## SEALENTS & ADHESIVES



Description	Code
EPDM Rubber Profile	S21-EPDM-50m

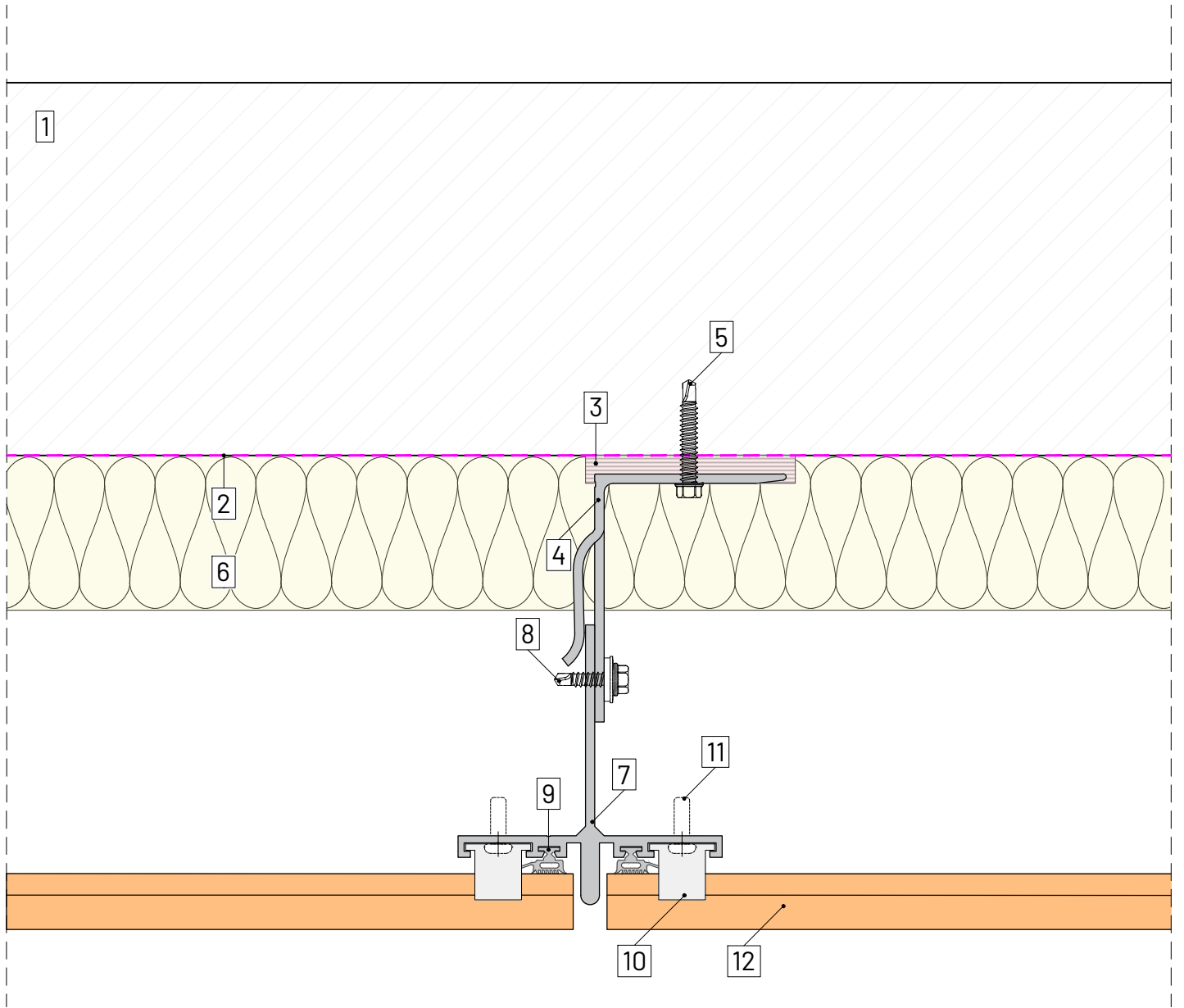

**LEGEND**

**1.** SUBSTRATE **2.** BREATHER MEMBRANE **3.** THERMAL ISOLATOR **4.** FORTIS HELPING HAND BRACKET **5.** PRIMARY FIXING  
**6.** THERMAL INSULATION **7.** T / L / CORNER PROFILE **8.** SELF DRILL SCREW **9.** EPDM RUBBER PROFILE **10.** CLIP **11.** RIVET/SCREW  
**12.** CLADDING (DOUBLE SKIN TERRACOTTA)



www.cladmate.co.uk | technical@cladmate.co.uk

system title:  
**DOUBLE SKIN TERRACOTTA  
 CLADDING SUPPORT SYSTEM**

drawing title:  
**PLAN DETAIL**

date:  
 Sep 2021

scale:  
 NTS  
 @A4

system no:  
 CMS-21

drawing no: rev:  
 01 03

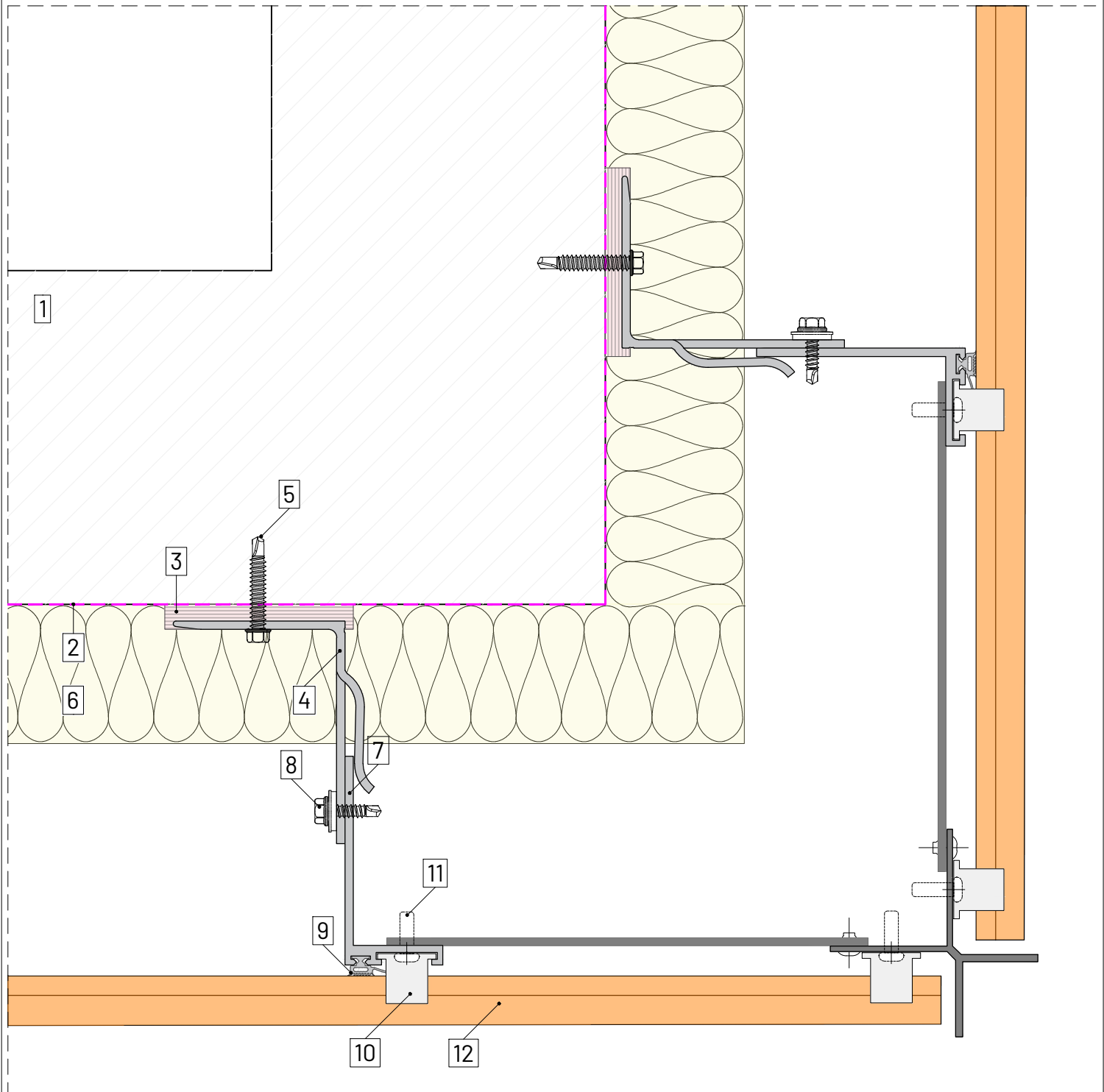

**LEGEND**

1. SUBSTRATE 2. BREATHER MEMBRANE 3. THERMAL ISOLATOR 4. FORTIS HELPING HAND BRACKET 5. PRIMARY FIXING  
 6. THERMAL INSULATION 7. T / L / CORNER PROFILE 8. SELF DRILL SCREW 9. EPDM RUBBER PROFILE 10. CLIP 11. RIVET/SCREW  
 12. CLADDING (DOUBLE SKIN TERRACOTTA)



www.cladmate.co.uk | technical@cladmate.co.uk

system title:  
**DOUBLE SKIN TERRACOTTA  
 CLADDING SUPPORT SYSTEM**

drawing title:  
**EXTERNAL CORNER DETAIL I**

date:  
 Sep 2021

scale:  
 NTS  
 @A4

system no:  
 CMS-21

drawing no: rev:  
 02A 03

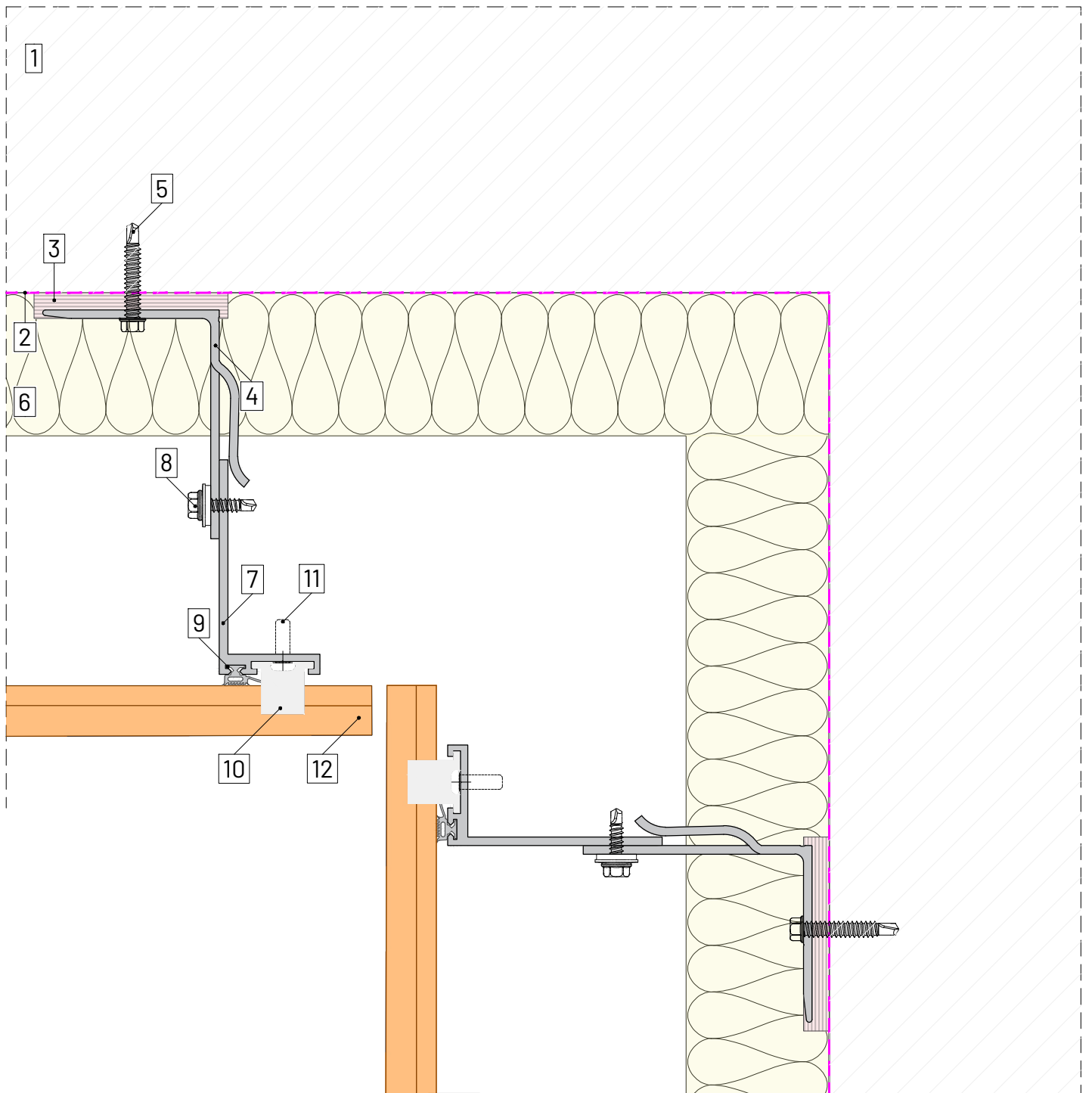

**LEGEND**

**1.** SUBSTRATE **2.** BREATHER MEMBRANE **3.** THERMAL ISOLATOR **4.** FORTIS HELPING HAND BRACKET **5.** PRIMARY FIXING  
**6.** THERMAL INSULATION **7.** T / L / CORNER PROFILE **8.** SELF DRILL SCREW **9.** EPDM RUBBER PROFILE **10.** CLIP **11.** RIVET/SCREW  
**12.** CLADDING (DOUBLE SKIN TERRACOTTA)



www.cladmate.co.uk | technical@cladmate.co.uk

system title:  
**DOUBLE SKIN TERRACOTTA  
 CLADDING SUPPORT SYSTEM**

drawing title:  
**INTERNAL CORNER DETAIL**

date:  
 Sep 2021

scale:  
 NTS  
 @A4

system no:  
 CMS-21

drawing no: 03  
 rev: 03

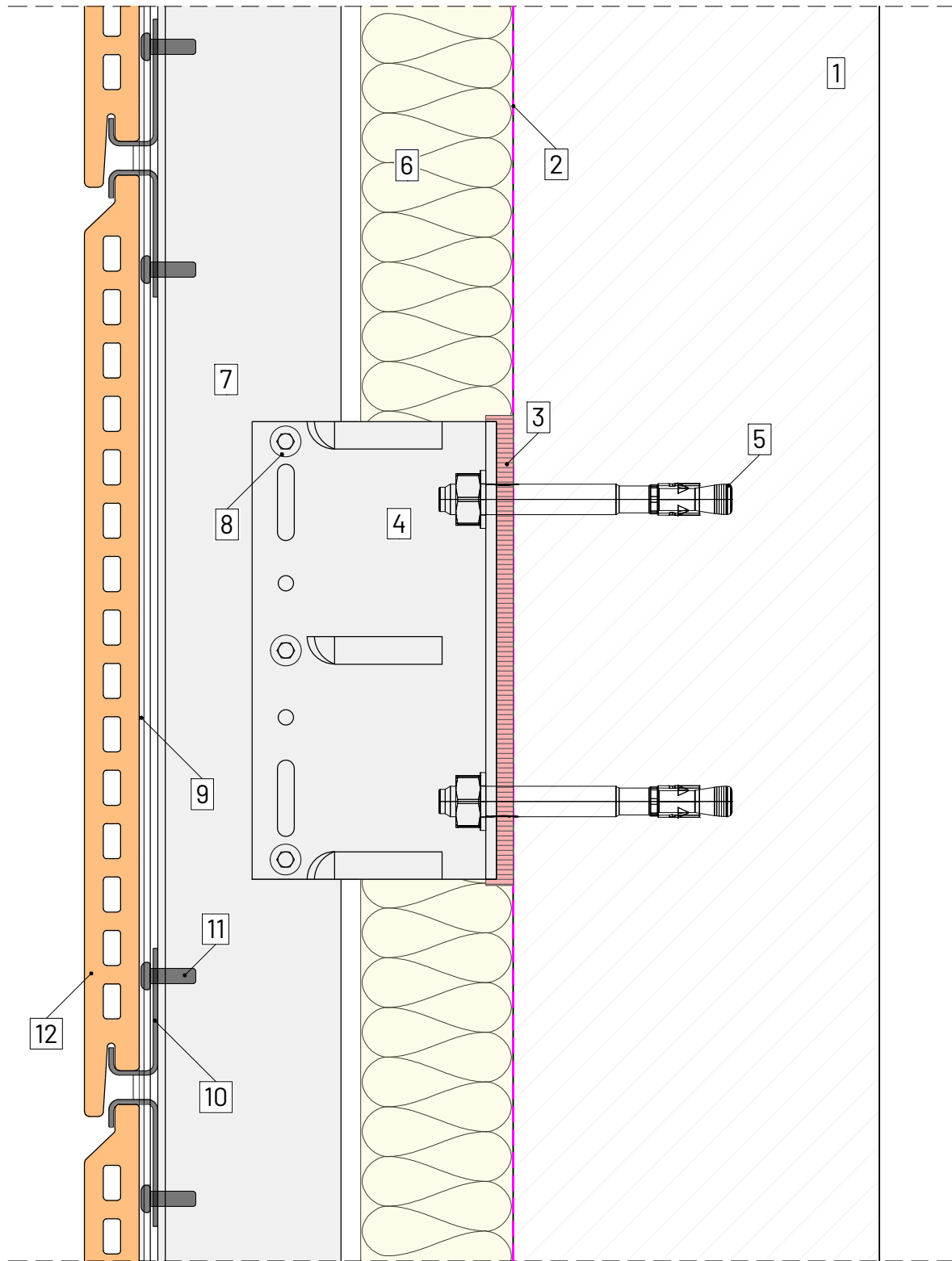

**LEGEND**

**1.** SUBSTRATE **2.** BREATHER MEMBRANE **3.** THERMAL ISOLATOR **4.** FORTIS HELPING HAND BRACKET **5.** PRIMARY FIXING  
**6.** THERMAL INSULATION **7.** T / L / CORNER PROFILE **8.** SELF DRILL SCREW **9.** EPDM RUBBER PROFILE **10.** CLIP **11.** RIVET/SCREW  
**12.** CLADDING (DOUBLE SKIN TERRACOTTA)



www.cladmater.co.uk | technical@cladmater.co.uk

system title:  
**DOUBLE SKIN TERRACOTTA  
 CLADDING SUPPORT SYSTEM**

drawing title:  
**VERTICAL SECTION DETAIL**

date:  
 Sep 2021

scale:  
 NTS  
 @A4

system no:  
 CMS-21

drawing no: 04  
 rev: 03

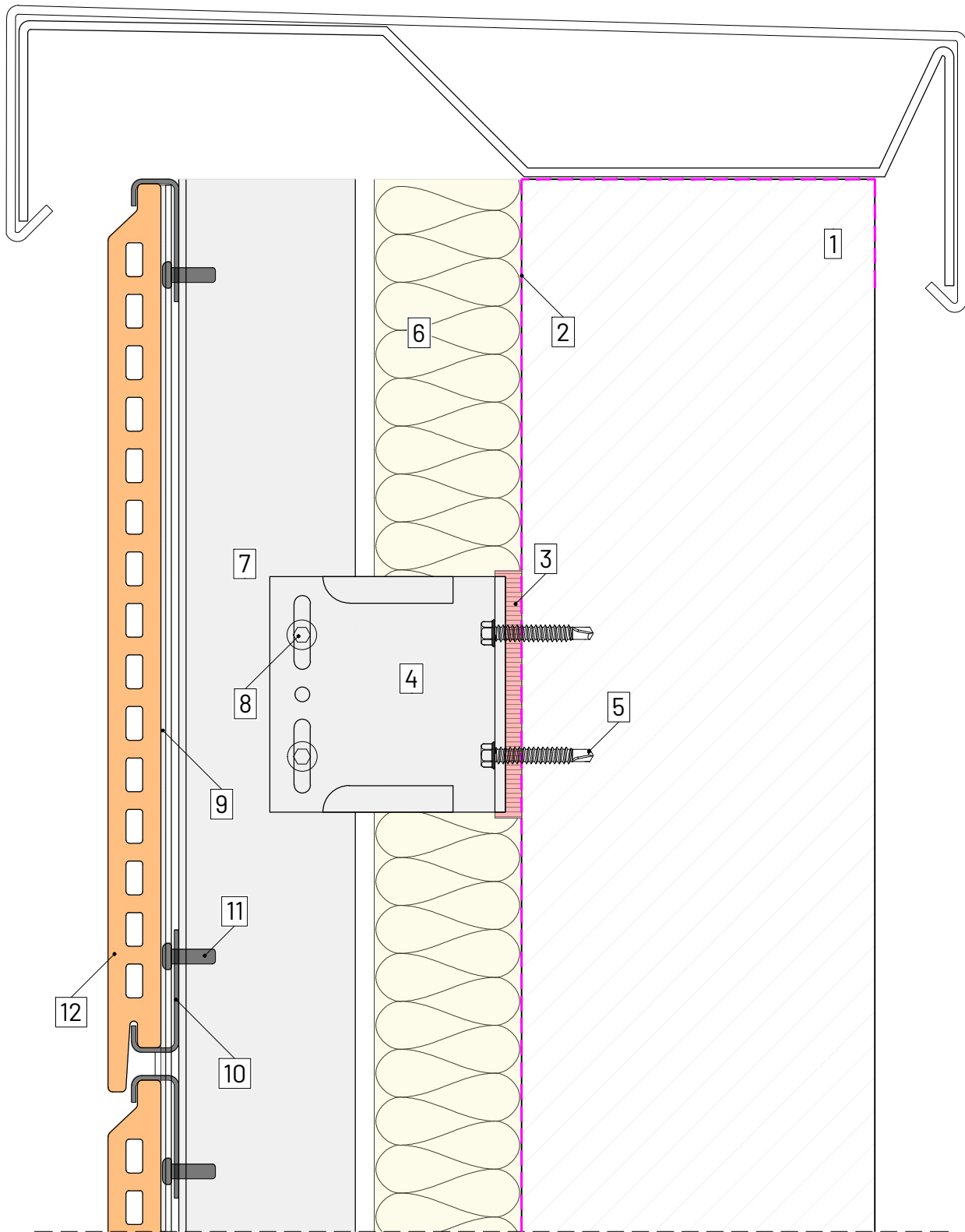

**LEGEND**

1. SUBSTRATE 2. BREATHER MEMBRANE 3. THERMAL ISOLATOR 4. FORTIS HELPING HAND BRACKET 5. PRIMARY FIXING  
 6. THERMAL INSULATION 7. T / L / CORNER PROFILE 8. SELF DRILL SCREW 9. EPDM RUBBER PROFILE 10. CLIP 11. RIVET/SCREW  
 12. CLADDING (DOUBLE SKIN TERRACOTTA)



www.cladmate.co.uk | technical@cladmate.co.uk

system title:  
**DOUBLE SKIN TERRACOTTA  
 CLADDING SUPPORT SYSTEM**

drawing title:  
**PARAPET DETAIL**

date:  
 Sep 2021

scale:  
 NTS  
 @A4

system no:  
 CMS-21

drawing no: 05 rev: 03

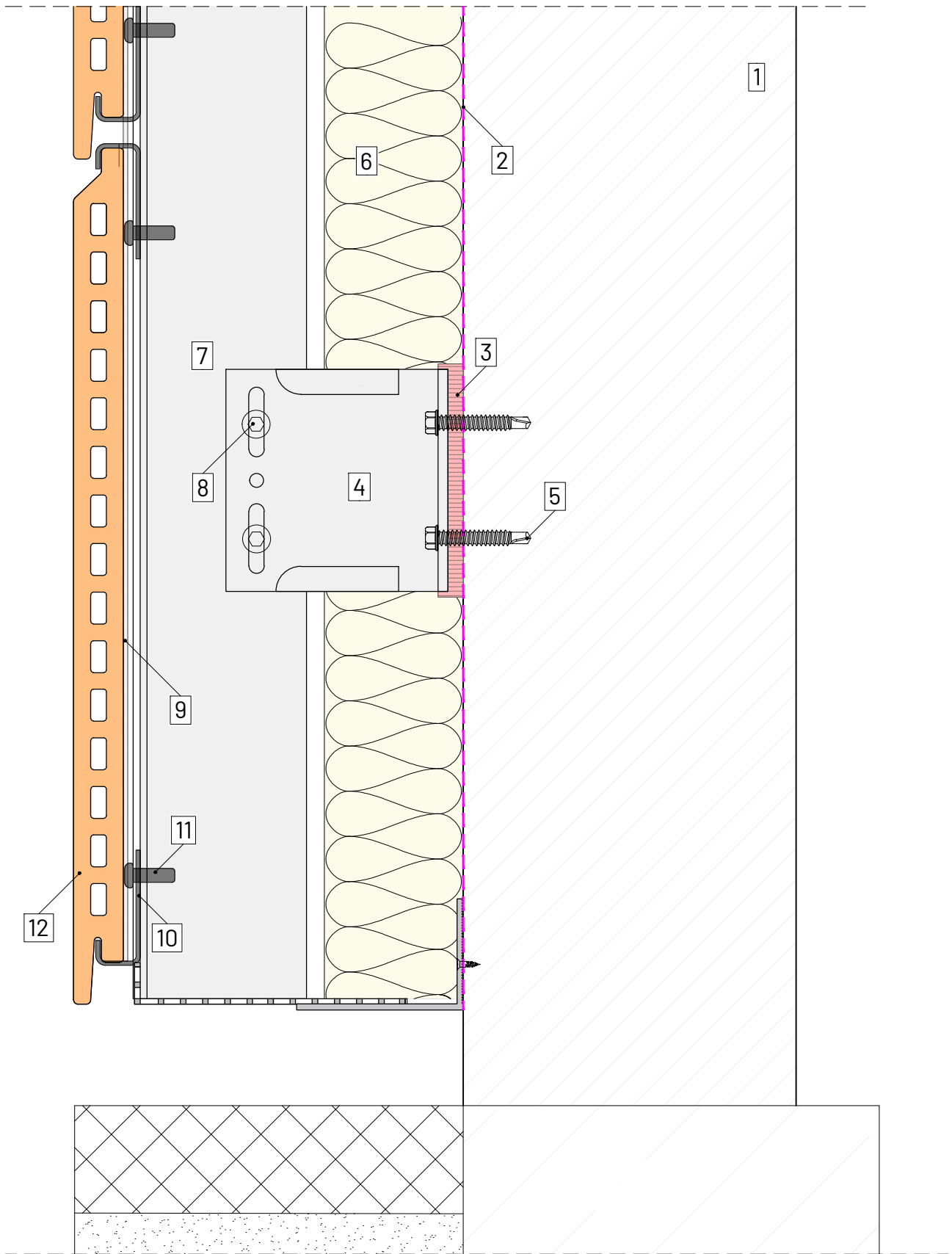

**LEGEND**

- 1.** SUBSTRATE **2.** BREATHER MEMBRANE **3.** THERMAL ISOLATOR **4.** FORTIS HELPING HAND BRACKET **5.** PRIMARY FIXING
- 6.** THERMAL INSULATION **7.** T / L / CORNER PROFILE **8.** SELF DRILL SCREW **9.** EPDM RUBBER PROFILE **10.** CLIP **11.** RIVET/SCREW
- 12.** CLADDING (DOUBLE SKIN TERRACOTTA)



www.cladmate.co.uk | technical@cladmate.co.uk

system title:  
**DOUBLE SKIN TERRACOTTA  
 CLADDING SUPPORT SYSTEM**

drawing title:  
**BASE DETAIL**

date:  
 Sep 2021

scale:  
 NTS  
 @A4

system no:  
 CMS-21

drawing no: rev:  
 06 03

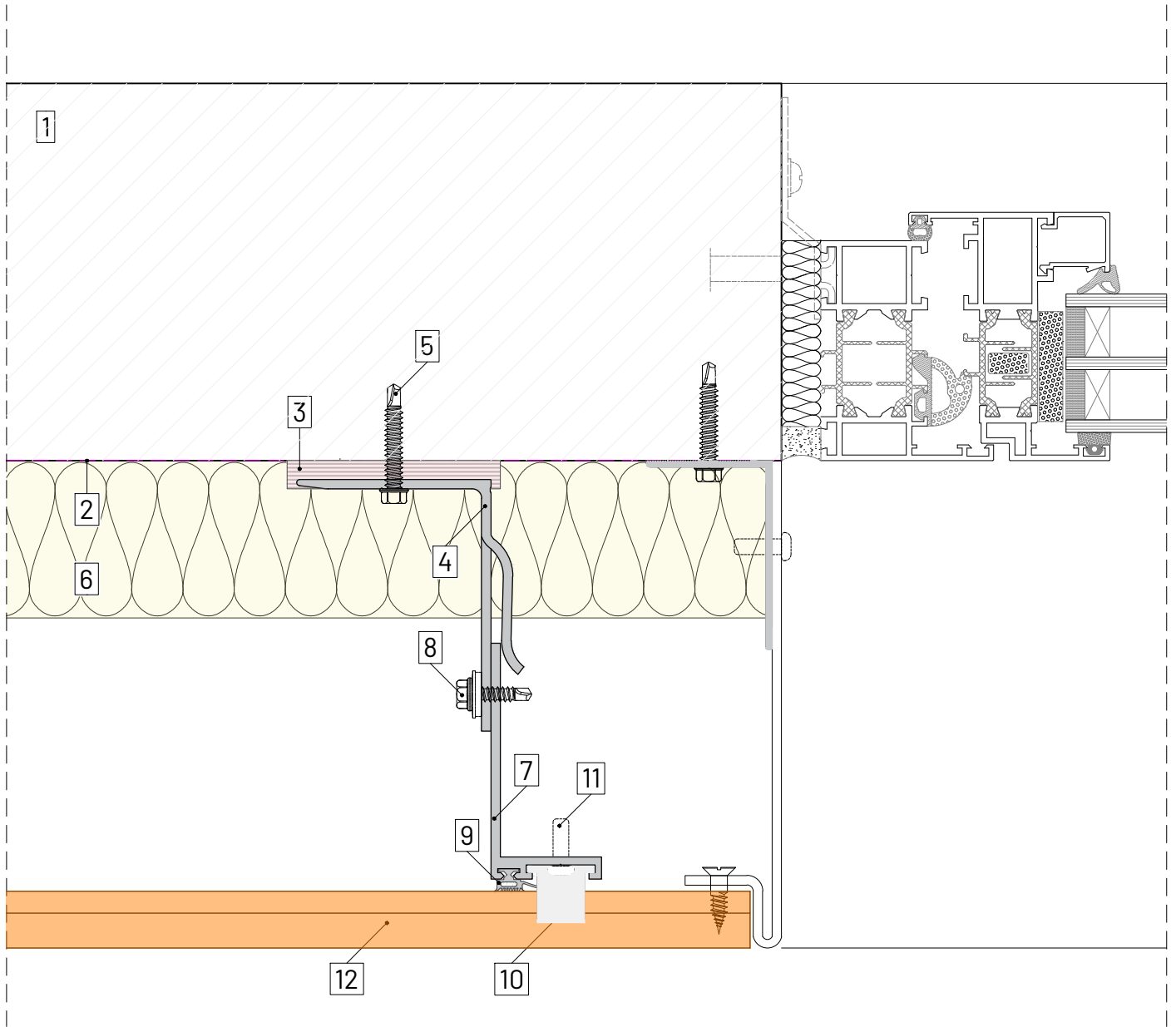

**LEGEND**

- 1.** SUBSTRATE **2.** BREATHER MEMBRANE **3.** THERMAL ISOLATOR **4.** FORTIS HELPING HAND BRACKET **5.** PRIMARY FIXING  
**6.** THERMAL INSULATION **7.** T / L / CORNER PROFILE **8.** SELF DRILL SCREW **9.** EPDM RUBBER PROFILE **10.** CLIP **11.** RIVET/SCREW  
**12.** CLADDING (DOUBLE SKIN TERRACOTTA)



www.cladmate.co.uk | technical@cladmate.co.uk

system title:  
**DOUBLE SKIN TERRACOTTA  
 CLADDING SUPPORT SYSTEM**

drawing title:  
**WINDOW REVEAL DETAIL**

date:  
 Sep 2021

scale:  
 NTS  
 @A4

system no:  
 CMS-21

drawing no: rev:  
 07 03

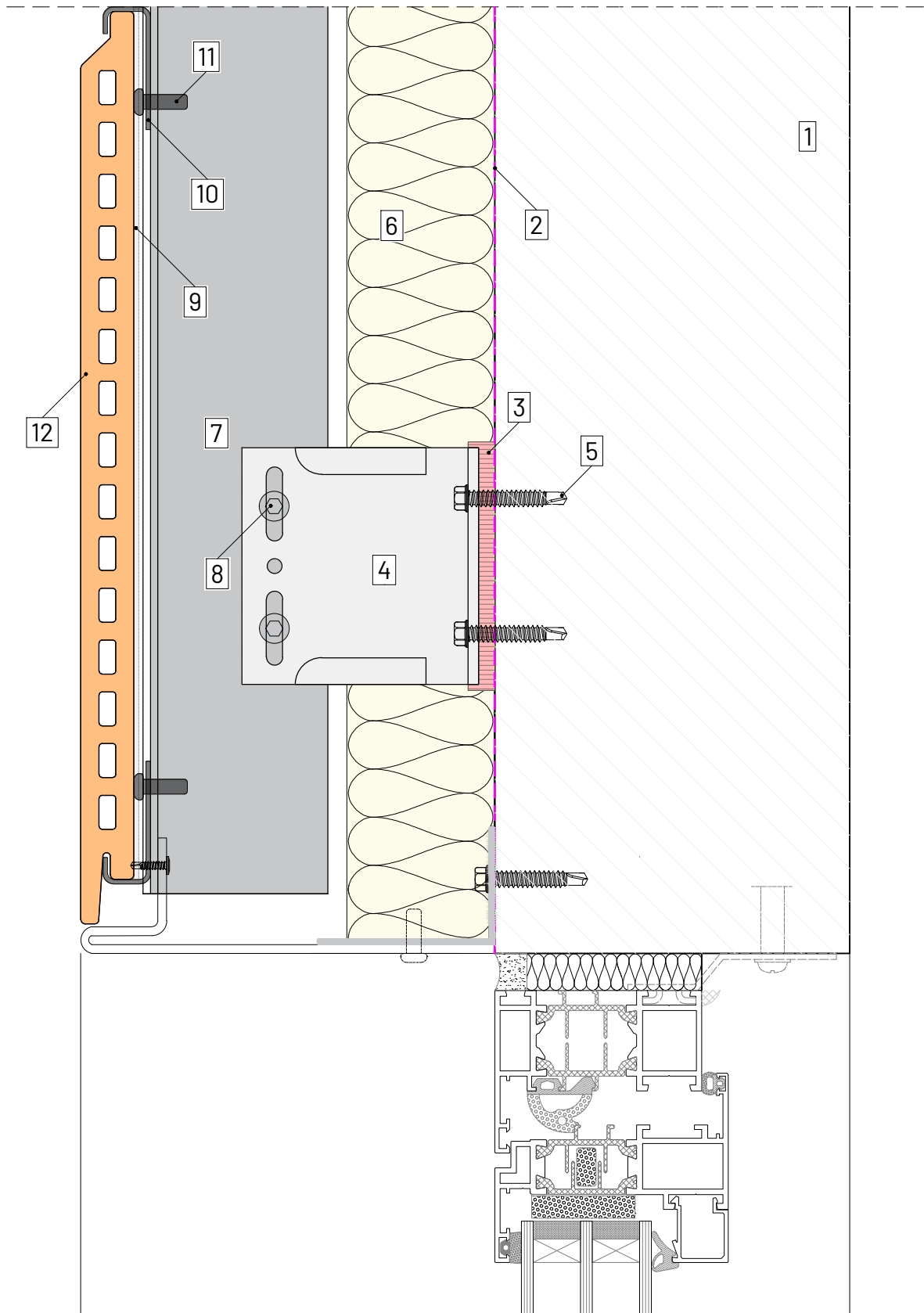

**LEGEND**

**1. SUBSTRATE 2. BREATHER MEMBRANE 3. THERMAL ISOLATOR 4. FORTIS HELPING HAND BRACKET 5. PRIMARY FIXING  
 6. THERMAL INSULATION 7. T / L / CORNER PROFILE 8. SELF DRILL SCREW 9. EPDM RUBBER PROFILE 10. CLIP 11. RIVET/SCREW  
 12. CLADDING (DOUBLE SKIN TERRACOTTA)**



www.cladmate.co.uk | technical@cladmate.co.uk

system title:  
**DOUBLE SKIN TERRACOTTA  
 CLADDING SUPPORT SYSTEM**

drawing title:  
**WINDOW HEAD DETAIL**

date:  
 Sep 2021

scale:  
 NTS  
 @A4

system no:  
 CMS-21

drawing no: 08  
 rev: 03

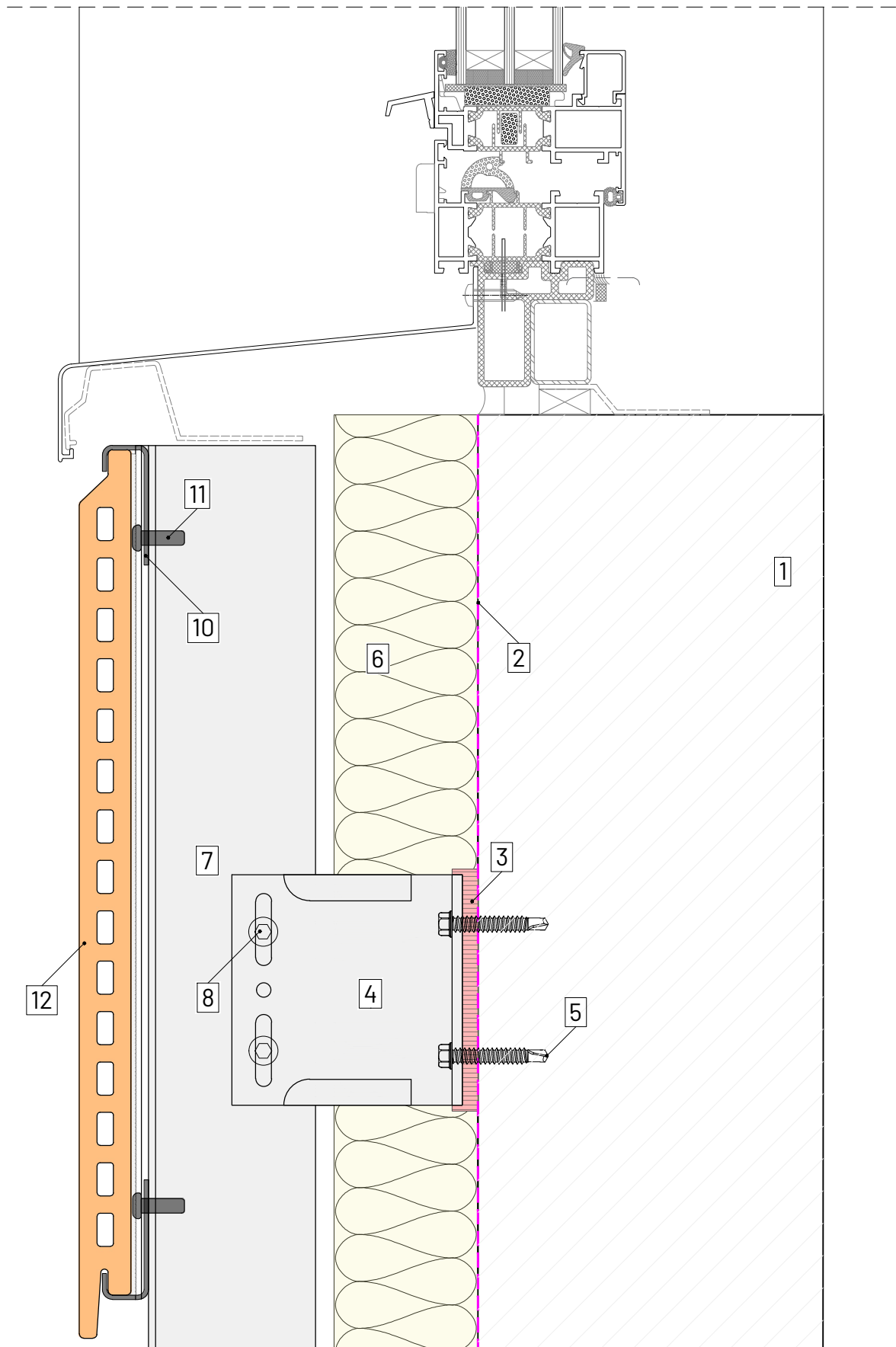

**LEGEND**

- 1. SUBSTRATE 2. BREATHER MEMBRANE 3. THERMAL ISOLATOR 4. FORTIS HELPING HAND BRACKET 5. PRIMARY FIXING**  
**6. THERMAL INSULATION 7. T / L / CORNER PROFILE 8. SELF DRILL SCREW 9. EPDM RUBBER PROFILE 10. CLIP 11. RIVET/SCREW**  
**12. CLADDING (DOUBLE SKIN TERRACOTTA)**



www.cladmate.co.uk | technical@cladmate.co.uk

system title:  
**DOUBLE SKIN TERRACOTTA  
 CLADDING SUPPORT SYSTEM**

drawing title:  
**WINDOW CILL DETAIL**

date:  
 Sep 2021

scale:  
 NTS  
 @A4

system no:  
 CMS-21

drawing no: rev:  
 09 03