



MFSLIP[®]

CMS40 Mechanically Fixed
Brick Slip Cladding System

Bricks Reimagined

Installation Guide

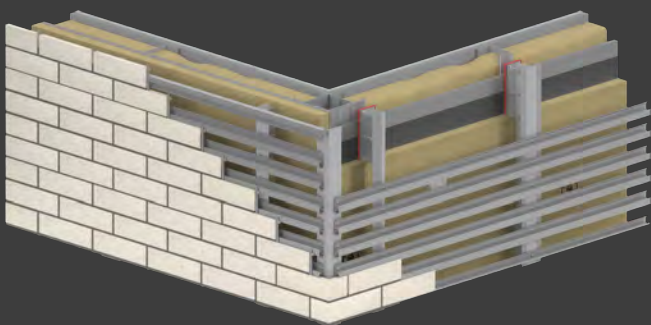

Cladmate Facade Systems

Cladmate Facade Systems designs and manufactures a comprehensive range of facade solutions. We offer adaptable rainscreen and EWI systems, along with high-performance stone wool insulation, for a complete range of facade solutions. Our bespoke components ensure seamless integration with diverse cladding materials and building types. With a strong technical team, we offer collaborative support from project design through completion.

MF Slip CMS40 Mechanically Fixed Brick Slip Cladding System

The CMS40 MF Slip Mechanically Fixed Brick Slip Cladding Support System delivers the traditional look of brick with the versatility of a rainscreen system, offering enhanced thermal performance, durability, and unparalleled design freedom. Its A1 fire rating ensures suitability for buildings of any height, including those above 18 meters. This installation guide provides a comprehensive overview of CMS40 components and step-by-step instructions for a successful installation.

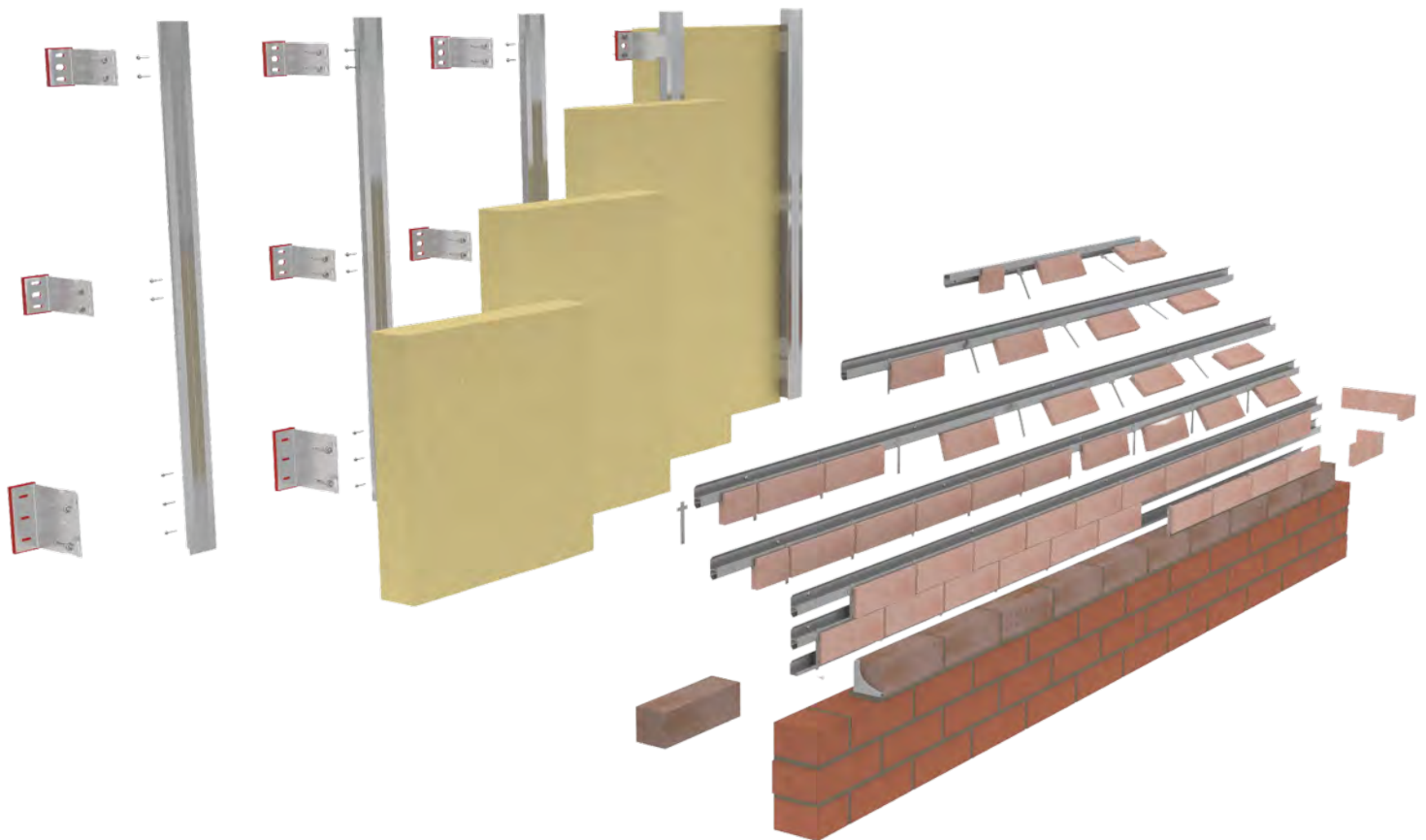

Disclaimer

- This installation guide provides general information and guidance on the use of Cladmate Cladding Support Systems. You must always prioritise the specific instructions and specifications provided by architects, engineers, facade experts, and installers involved in your project. These instructions supersede any information in this guide.
- Please ensure you are using the most up-to-date version of this guide. Check for updates on our website www.cladmate.co.uk.
- Drawings and illustrations in this guide are for visual reference only. Do not use them for scaling or precise measurements.
- Cladmate Facade Systems Ltd makes every effort to ensure the accuracy of this guide. However, unintentional errors may occur. Cladmate is not liable for any damages, losses, or claims arising from the use of this guide or its contents.
- This document is the property of Cladmate Facade Systems Ltd. Unauthorised copying or distribution is prohibited.

Fortis Helping Hand Brackets

Cladmate Fortis Helping Hand Brackets form the essential foundation for rainscreen cladding systems, working alongside vertical rails to establish robust support. They are designed to transfer dead and wind loads from the cladding panels to the building substrate, ensuring the facades overall stability and long-term durability.

Cladmate Helping Hand Brackets offer a comprehensive range of configurations to suit diverse project needs and most substrates. Helping Hand Brackets are available in single and double options, sizes from 40mm to 300mm, with complementary extension pieces, corner brackets, and vertical-to-horizontal adaptors. Refer to the table below to determine the specific brackets and configurations required for your project.

Single and double brackets are designed to work in conjunction within most rainscreen cladding systems. The ratio of single and double brackets used will depend on the specific load calculations and design layout of a project.

Cladmate offers brackets in both aluminium and stainless steel to accommodate various project requirements. All brackets are anodised for enhanced durability. Mill finish and powder coating. Options are available upon request for additional protection or customisation.



RAINCLAD[®]

High-Performance A1 Non-Combustible Thermal and Acoustic Insulation for Rainscreen Cladding Applications.

Whatever your external wall insulation requirements may be, Rainclad is the answer.



A1

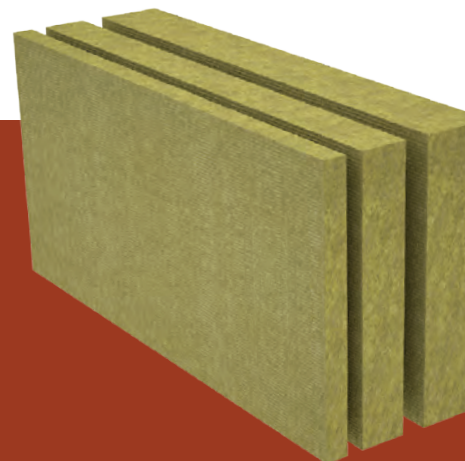

Single Bracket - Universal

For steel, timber & concrete substrate
2 x 6.5 mm slot, 1 x 11mm slot

Product Code	Size
	(mm)
CMF-SB40-UN	40
CMF-SB60-UN	60
CMF-SB80-UN	80
CMF-SB100-UN	100
CMF-SB120-UN	120
CMF-SB140-UN	140
CMF-SB160-UN	160
CMF-SB180-UN	180
CMF-SB200-UN	200
CMF-SB220-UN	220
CMF-SB240-UN	240
CMF-SB270-UN	270
CMF-SB300-UN	300

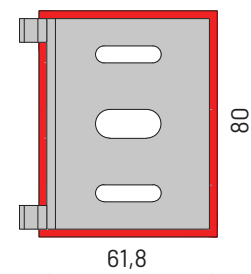

Double Bracket 6.5mm

For steel & timber substrate
2 x 6.5 mm slot, 1 x 11mm slot

Product Code	Size
	(mm)
CMF-DB40-6.5	40
CMF-DB60-6.5	60
CMF-DB80-6.5	80
CMF-DB100-6.5	100
CMF-DB120-6.5	120
CMF-DB140-6.5	140
CMF-DB160-6.5	160
CMF-DB180-6.5	180
CMF-DB200-6.5	200
CMF-DB220-6.5	220
CMF-DB240-6.5	240
CMF-DB270-6.5	270
CMF-DB300-6.5	300

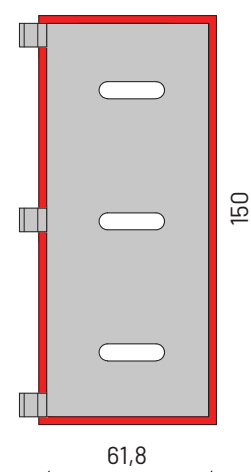

Double Bracket 11mm

For masonry & concrete substrate
2 x 6.5 mm slot, 1 x 11mm slot

Product Code	Size
	(mm)
CMF-DB40-11	40
CMF-DB60-11	60
CMF-DB80-11	80
CMF-DB100-11	100
CMF-DB120-11	120
CMF-DB140-11	140
CMF-DB160-11	160
CMF-DB180-11	180
CMF-DB200-11	200
CMF-DB220-11	220
CMF-DB240-11	240
CMF-DB270-11	270
CMF-DB300-11	300

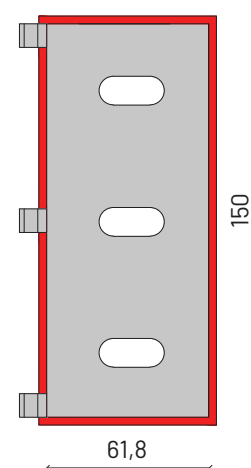

CMS40 | System Components

Corner Bracket Holder

The Corner Bracket holder is designed for external corner applications. It provides a secure mounting point for the helping hand brackets and corner rail, ensuring a robust corner finish for your cladding.

Product Code	Size (mm)
CMB48-48-80	80
CMB48-48-150	150

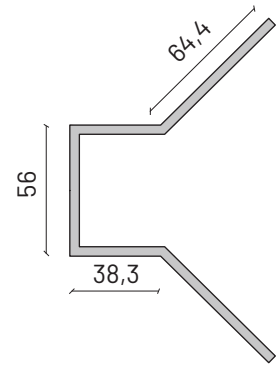

Vertical To Horizontal Adaptor

The V2H Adaptor enables secure horizontal mounting of T/L rails onto Helping Hand Brackets.

Product Code	Size (mm)
CMF-V2HA	80

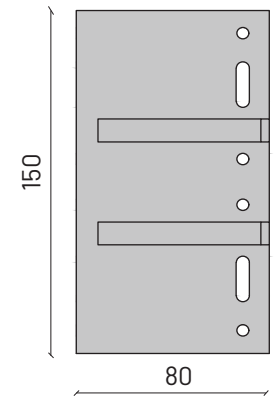
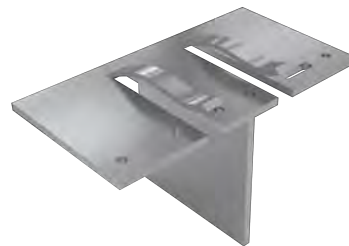

Extension Bracket

The Extension Brackets increase the projection of Helping Hand Brackets, effectively extending the cladding zone. Attached directly to Helping Hand Brackets, they offer up to an additional 80mm of extension. This versatile solution is compatible with the entire range of Helping Hand Bracket.

Product Code	Size
CMF-SBEX	Single
CMF-DBEX	Double

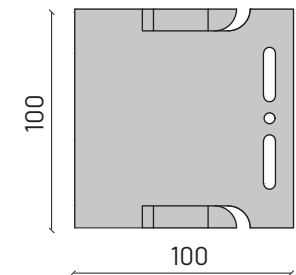
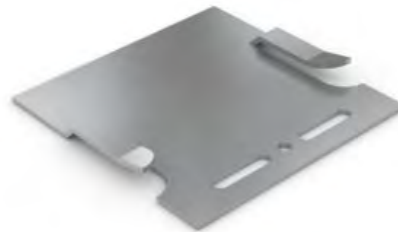

Thermal Isolator

Thermal Isolators minimise thermal bridging through the Helping Hand Brackets, enhancing the overall thermal performance. Included as standard with Helping Hand Brackets, they are also available for separate purchase to suit custom applications.

Product Code	Size
CMP-SG-00	Single
CMP-DB-00	Double

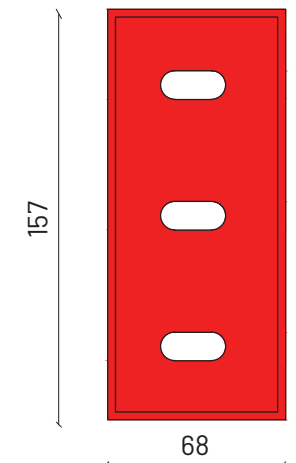

Profiles & Rails

The profiles are suitable for mechanical fixing of cladding elements by means of rivet or screw, the rails along with brackets forms a substructure and transfer the load of the brick slips and wind loads on to the substrate.

The T and L rails are most used in connection with helping hand brackets to create a subframe and based on the application requirements Z / Omega profiles can be used in place of L / T rails as vertical mullions. Please contact Cladmate Technical Team for further information and custom solutions.

Profiles available in Aluminium and Stainless-steel. Powder coating and anodising also available upon request.

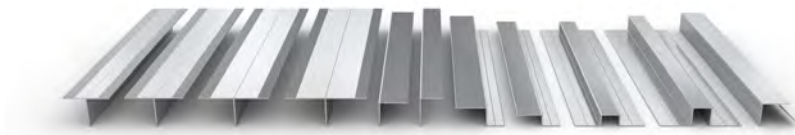

L Profile

Product Code	Description
LP50-50-2.2-3000	L Profile 50 x 50 x 2.2 x 3000mm
LP50-50-2.2-6000	L Profile 50 x 50 x 2.2 x 6000mm
LP60-40-2.2-3000	L Profile 60 x 40 x 2.2 x 3000mm
LP60-40-2.2-6000	L Profile 60 x 40 x 2.2 x 6000mm
LP60-40-2.5-3000	L Profile 60 x 40 x 2.5 x 3000mm
LP60-40-2.5-6000	L Profile 60 x 40 x 2.5 x 6000mm

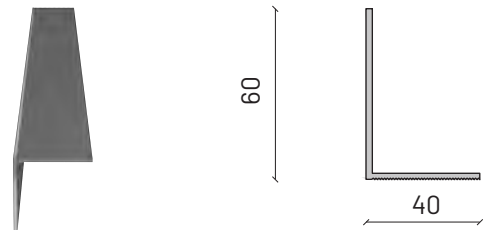

T Profile

Product Code	Description
TP60-80-2.2-3000	T Profile 60 x 80 x 2.2 x 3000mm
TP60-80-2.2-6000	T Profile 60 x 80 x 2.2 x 6000mm
TP60-100-2.2-3000	T Profile 60 x 100 x 2.2 x 3000mm
TP60-100-2.2-6000	T Profile 60 x 100 x 2.2 x 6000mm
TP60-120-2.2-3000	T Profile 60 x 120 x 2.2 x 3000mm
TP60-120-2.2-6000	T Profile 60 x 120 x 2.2 x 6000mm
TP60-140-2.2-3000	T Profile 60 x 140 x 2.2 x 3000mm
TP60-140-2.2-6000	T Profile 60 x 140 x 2.2 x 6000mm

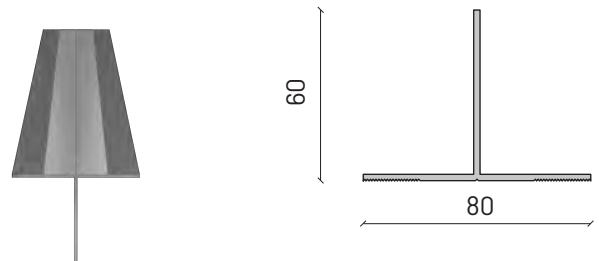

Omega Profile

Product Code	Description
CMOM-25-120-2.4-3000	25mm Omega Profile 25 x 120 x 2.4 x 3000mm
CMOM-25-120-2.4-6000	25mm Omega Profile 25 x 120 x 2.4 x 6000mm
CMOM-40-140-2.4-3000	40mm Omega Profile 40 x 140 x 2.4 x 3000mm
CMOM-40-140-2.4-6000	40mm Omega Profile 40 x 140 x 2.4 x 6000mm

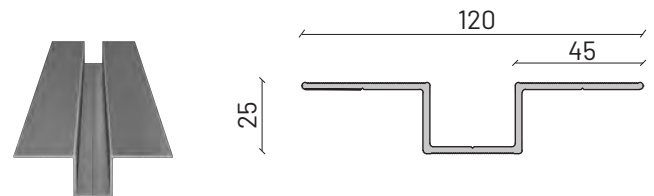

Z Profile

Product Code	Description
CMZP-25-45-30-2.4-3000	25mm Z Profile 25 x 45 x 30 x 2.4 x 3000mm
CMZP-25-45-30-2.4-6000	25mm Z Profile 25 x 45 x 30 x 2.4 x 3000mm
CMZP-40-55-30-2.4-3000	40mm Z Profile 40 x 55 x 30 x 2.4 x 3000mm
CMZP-40-55-30-2.4-6000	40mm Z Profile 40 x 55 x 30 x 2.4 x 6000mm

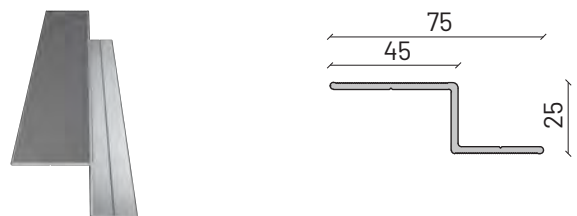

Corner Profile

Product Code	Description
CMKP-48-48-3000	Corner Rail 3000mm
CMKP-48-48-6000	Corner Rail 6000mm

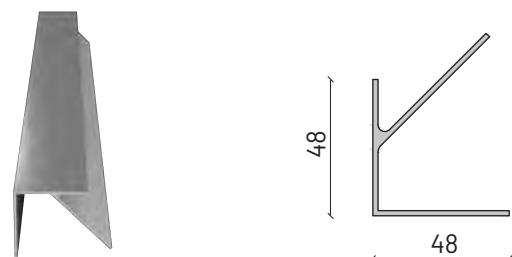

CMS40 | System Components

Brackets & Rail Configurations

While all Cladmate Helping Hand Brackets feature both fixed and slotted points for attaching vertical rails, there's a key difference in the primary use of single and double brackets:

1- Single Helping Hand Brackets:

Designed with a focus on a single slotted point, these brackets are ideal for absorbing wind loads and providing flexibility within the system. They are typically used throughout the majority of the bracket arrangement.

2- Double Helping Hand Brackets:

Prioritizing two fixed points, these brackets excel at providing stability and supporting substantial vertical (dead) loads. They are commonly used at the top of the system and other locations where additional rigidity is necessary.

Bracket to Rail Adjustment

Size (mm) A	Thickness (mm) B	Range (mm)	
		Minimum	Maximum
300	4	305	345
270	4	275	315
240	4	245	285
220	4	225	265
200	4	205	245
180	3	185	225
160	3	165	205
140	3	145	185
120	3	125	165
100	3	105	145
80	3	85	125
60	3	62	102
40	3	40	62
Extension	3	-	+80

1- All dimensions are in mm.

2- The Thermal Isolator thickness is not included in the range and when using the same 5mm need to be added to the total range.

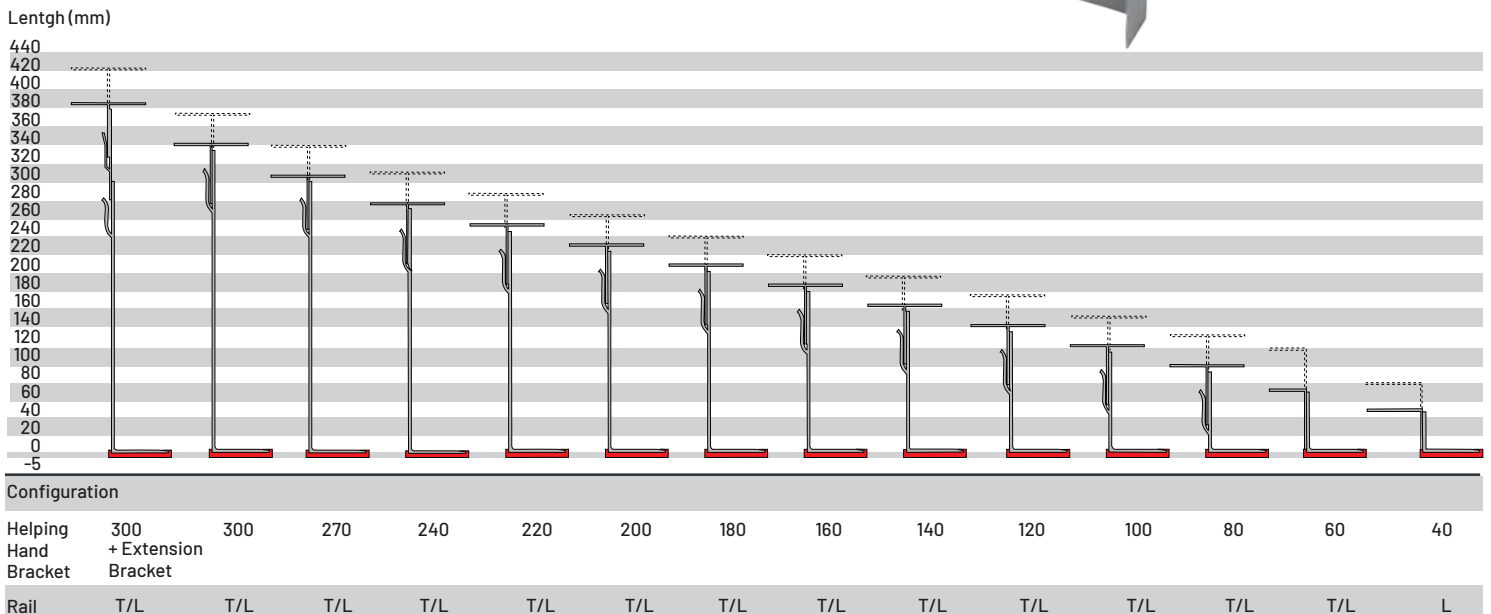

1- All dimensions are in mm.

2- 40mm & 60mm brackets range is shown with the combination of L- Profile, which also works with T- Profiles.

Horizontal Support Mid Rail

Product Code	Description
RS-HSR-3000	Horizontal Support Mid Rail 3000mm
RS-HSR-6000	Horizontal Support Mid Rail 6000mm
RS-HSR-800	Corner Horizontal Support Mid Rail 800mm

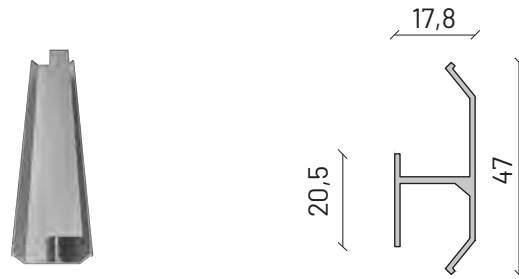

Horizontal Support Top Rail

Product Code	Description
RS-HSER-3000	Horizontal Top Rail 3000mm
RS-HSER-6000	Horizontal Top Rail 6000mm

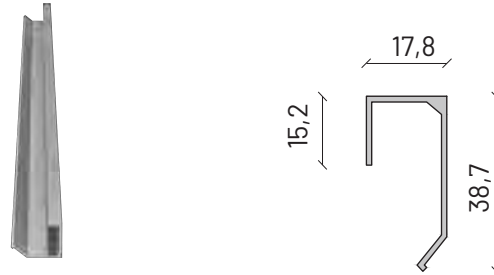

Horizontal Support Bottom Rail

Product Code	Description
RS-HSB-3000	Horizontal Bottom Rail 3000mm
RS-HSB-6000	Horizontal Bottom Rail 6000mm

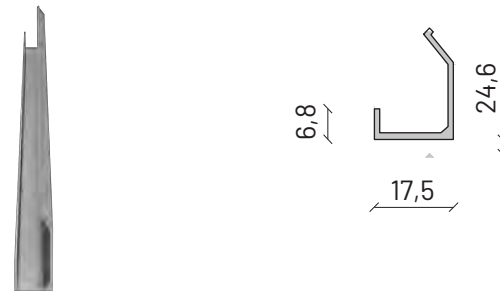

Brick Spacer

Product Code	Description
RS-VPC-15	Vertical Pointing Plug

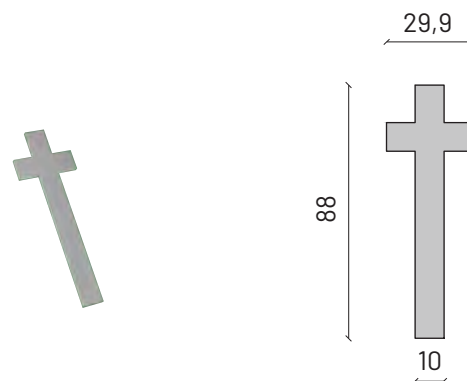

Rail Gauge

Product Code	Description
CMS40 - RAIL GAUGE	Horizontal Rail Gauge



CMS40 | System Components

Brick Slips

The CMS40 MF Brick Slip Cladding system is compatible with a wide range of brick types in various colours and textures. It accommodates metric, imperial, and linear brick slip formats with thicknesses ranging from 22mm (± 2 mm) to 65mm (± 2 mm). The system supports most common types of brick bonds.

Brick slips have grooves along the top and bottom edges designed for secure locking into horizontal rails. Cladmate offers brick slip cutting and grooving services for most brick types, providing added convenience.

To ensure optimal performance and safety, brick slips used with the CMS40 system should meet the following requirements in accordance with BS EN 771-1: 2011:

- A reaction to fire classification of A1
- Frost resistance with a durability rating of F2
- Soluble salts rating of S2
- A maximum water absorption of 21%

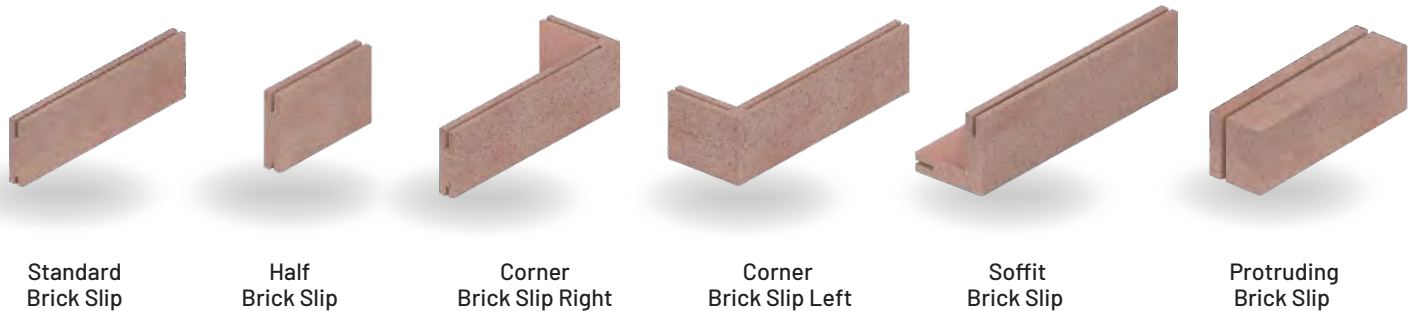

Pointing Mortar

The CMS40 MF Brick Slip Cladding system can accommodate both lime-based and cement-based pointing mortars, available in a range of colours to complement the brick slips.

Lime-based Mortar: Made with hydrated lime, sand, and sometimes other materials like ground granulated furnace slag. Lime-based mortars are known for their flexibility and breathability.

Cement-based Mortar: Includes cement as a binder, along with graded fillers. Cement-based mortars offer increased strength and durability.



NESTCLAD offers specialised nesting solutions designed for seamless integration within your rainscreen cavity. Enhance biodiversity with these units, featuring built-in havens for bees, bats, and various birds. With NESTCLAD, your building project becomes an active part of the local ecosystem.



Bracket to Substrate Fixings:











The right choice of fixings will help to achieve the balanced load transfer and good structural hold. Make sure to use the specified fixings based on the substrate type as detailed below.

Rail to Profile Fixings:

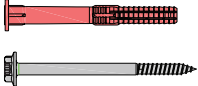
An individual rail will have only one fixed point bracket and the rest will be slotted to allow for expansion.

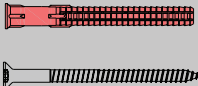
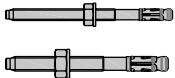
Fixed point brackets: The bracket to rail fixings is positioned at the bottom of the slotted holes to take the vertical deadload of the rail as well as the wind load.

Slotted point brackets: The bracket to rail fixings need to be positioned in the middle of the slotted holes to allow the rails to expand and contract. These brackets only take wind load and minimal deadload.

Fixing/Drive Tool	Application	Properties	
JT3-3-6.3 S16 Self Drilling Fastener Lengths 38-50mm  8mm Hex	Bracket to Metal Stud Ensure each single and double bracket has two fasteners. Place the fasteners in the smaller 6.5mm slotted holes.	A2 Stainless steel bi-met fastener for bracket and SFS from 1.2mm - 3.0mm in thickness.	
JT3-2-6.5 x 50 Self Drilling Fastener Length 50-80mm  8mm Hex	Bracket to Timber Stud Ensure each single and double bracket has two fasteners. Place the fasteners in the smaller 6.5mm slotted holes.	A2 Austenitic stainless steel fastener with carbon steel drill point. Min embedment depth 40mm.	
SDF-KB 10V Facade Anchor Lengths 50-220mm  Internal Drive T40	Bracket to Brickwork, Blockwork, Concrete Ensure each single and double bracket has two fasteners. Place the fasteners in the smaller 6.5mm slotted holes.	Zinc plated carbon steel/A4 Stainless steel set screw both used with a nylon plug. Min. embedment depth in concrete 40mm, in masonry 50mm.	
SDF-S 10H Facade Anchor Lengths 80-330mm  Internal Drive T40	Bracket to Perforated Brickwork Ensure single brackets has one fastener and double bracket has two fasteners. Place the fasteners in the 11mm slotted holes.	Zinc plated carbon steel used with a nylon plug. Min embedment depth 70mm.	
BA-E Plus 8 BA-E Plus 10 Through Bolt Lengths 57-163mm	Bracket to Dense Concrete Ensure single brackets has one fasteners and double bracket has two fasteners. Place the fasteners in the 11mm slotted holes.	A4 Stainless steel. Min embedment depth 48mm BA-E Plus 8 40mm BA-E Plus 10.	
JT4 4 4.8 S14 Length 19mm  8mm Hex	Rail to Bracket Ensure there are 2 fasteners per single bracket and 3 per double bracket.	Fully A2 Austenitic stainless steel.	
JT3 LT3 5.5 Length 25mm  T25	Rail to Rail Secure each T/L and support rail intersection with a single fastener.	Austenitic stainless steel fastener with carbon steel drillpoint.	

Step By Step Installation Guide

The CMS40 MF Brick Slip Rainscreen Cladding System offers an A1 fire rating, lightweight construction, and superior ventilated drainage. For optimal performance and to maintain warranty validity, strict adherence to Cladmate Facade Systems recommendations and this installation guide is essential. Before installation, ensure the substrate surface is dry, stable, and within permissible flatness tolerances. While the CMS40 system offers some flexibility for minor substrate adjustments, achieving the best final brick alignment and finish depends heavily on proper substrate preparation.

If required, install a high-performance, vapor-permeable breather membrane (by others) on the substrate for moisture protection. Follow the manufacturer's instructions for overlapping and sealing.

Step 1 - Fix Helping Hand Brackets

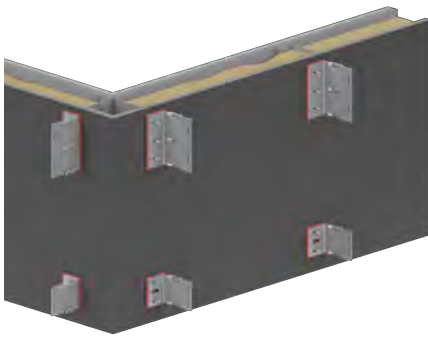

Each bracket is equipped with a thermal isolator as standard. Ensure this isolator is installed with the bracket to mitigate thermal bridging between the system and the wall. While not essential for the system's integrity, thermal isolators are recommended to improve energy efficiency and should be used unless otherwise specified. Mark bracket fixing points based on the bracket type and substrate material. Install brackets at a center-to-center distance of maximum 600mm horizontally and maximum 1200mm vertically on the substrate.

This is the recommended spacing, but the actual distances can vary based on project specifications and structural calculations. Use self-drilling screws for steel or timber substrates and self-drilling anchors for concrete or masonry walls.

For existing walls, a pull-out test is recommended to ensure the stability of the substrate and determine the appropriate fixing type and strength.

Step 2: Insulation

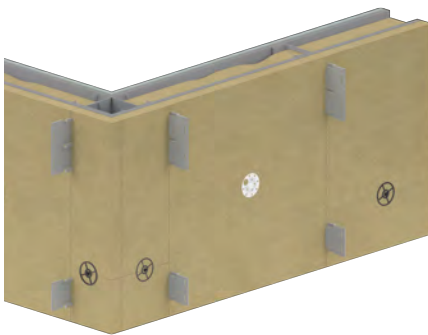

If specified by the project's requirements, choose thermal insulation designed for rainscreen systems to enhance the building's thermal and acoustic performance. Cladmate offers highperformance Rainclad™ Stone Mineral Wool Insulation. Install and stagger the insulation tightly between brackets as per the manufacturer's instructions, using compatible fixings.

Install cavity closers and/or fire barriers in conjunction with thermal insulation at locations specified by their respective manufacturers or designers.

Step 3: T/L Rails



Cut the vertical rails to the required length for each cladding zone. Each vertical rail will have a single fixed bracket connection. The remaining brackets should be connected via the slotted holes in the rails. This connection method allows for vertical movement of the system due to thermal expansion and contraction. Ensure the vertical rails are plumb and properly aligned with each other. Maintain a minimum 20mm expansion gap between the ends of adjoining vertical rails. This gap is essential to accommodate thermal movement of the cladding. The exact gap size may need adjustment based on the specific lengths of rails used in each joint.

For vertical brick applications, V2H adaptors should be used to install the rails horizontally.

Step 4: Horizontal Rails

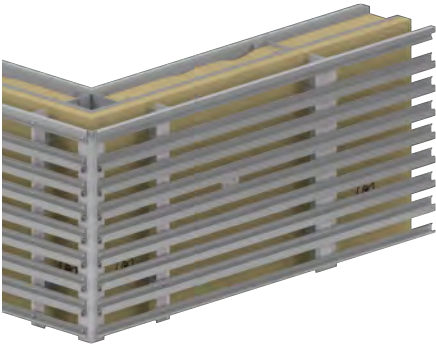

Fix the horizontal rails to the T/L rails at every junction. Maintain a consistent centre-to-centre distance that accommodates the brick slip height plus a 10mm mortar joint. Install horizontal top and bottom rails at the beginning and end of each cladding zone.

Begin installing the horizontal rails from the bottom and work upwards. Install the middle rails and finish with the penultimate rail in each zone. Conclude with a horizontal top rail at the end of each cladding zone.

To ensure precision and efficiency, use the template or CMS40 rail jig supplied by Cladmate. These tools will help you maintain accurate spacing and alignment of the horizontal rails.

For external corners, leave a 20mm gap on either side of the projected corner. Connect the perpendicular horizontal support rails using L-rails for seamless corner transitions. To simplify the installation of horizontal rails for external corners, you can use pre-notched corner horizontal support rails. These rails are specifically designed to work seamlessly with corner brick slips.

Step 5: Installing Brick Slips

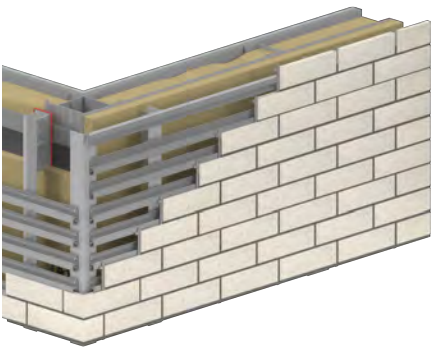

Before installation, ensure brick slips are in good form, reasonably free from cracks, damage to edges and corners, pebbles, and expansive particles of lime. All cut and grooved edges should be free from burrs and crisp. It is essential to verify that the specified brick slips are approved by Cladmate for use with the CMS40 system.

Install the brick slips firmly into place by tilting with a slight angle between the horizontal rails, using the upper retainers first and placing in the lower retainer of the horizontal rail. Ensure the cut side of the brick faces inwards and deeper grooved side of the brick slip faces upwards during installation. Insert the included metal t-shaped pointing plugs into the vertical joints between each brick. These spacers will establish a consistent 10mm wide joint for mortar application and help keep the brick slip above plumb.

The upstand of the horizontal rail profiles will automatically maintain a 10mm horizontal gap between the brick slips. Repeat this process for all remaining bricks to form the desired brick pattern within the cladding zone.

For external corners, use L-shaped corner brick slips (also known as pistols). These specialised slips create the illusion of full-sized bricks when transitioning around a corner. Choose the appropriate left-handed or right-handed notched rails based on the corner brick slips you are using. Internal corners can seamlessly use standard flat brick slips.

Step 6: Pointing Mortar

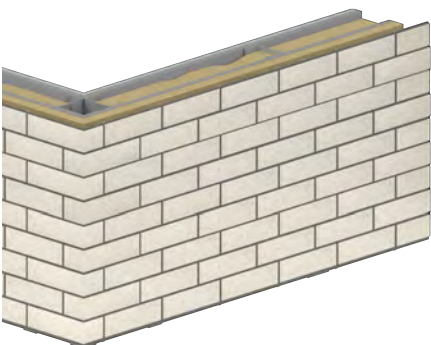

Once you have completed installing all the brick slips, use a mortar gun to inject the pointing mortar into all the horizontal and vertical 10mm joint gaps. Avoid applying pointing mortar in low temperatures (at or below 4°C). Begin by filling the horizontal gaps first, ensuring the joints are filled almost to the point of overflow with no voids or gaps. Allow the mortar to set until firm before tooling the applied mortar. After tooling, brush the area at a 45 degree angle to ensure the mortar remains flush with the brick edges.



Cladmate offers both on-site and off-site training to equip installers with the skills necessary for successful CMS40 installations – contact us at technical@cladmate.co.uk for more information.

Always use the tools recommended by Cladmate and adhere to standard construction safety practices. Personal protective equipment (PPE) is mandatory. This includes gloves, eye protection, hearing protection, and respiratory protection as needed (especially when cutting materials).

Sealing

To ensure weathertightness, seal all joints and abutments throughout the system according to the Cladmate installation guide. Sealing prevents water intrusion and potential damage.

Damage & Repairs

Damaged or broken slips can be easily replaced. Carefully remove the mortar pointing, lift the slip upwards to release it from the support rail, and slide it out base first. Damage to the horizontal supporting rails may require removal of several slips to access and fix the rail. If possible, reuse undamaged slips.

Maintenance

The CMS40 system generally requires minimal upkeep. As part of your maintenance routine, inspect mortar pointing every five years. For more specific guidance, contact Cladmate Technical Services at technical@cladmate.co.uk and provide your project details.

Recycling

Even with their long lifespan, consider these recycling options for clay building materials: reclaim and re-use, infrastructure fill and stabilizing material, or aggregate for concrete and mortars. Most aluminum in the CMS40 extrusions comes from recycled sources and can itself be recycled by a licensed company.

Adaptability

"Adaptable building" refers to structures easily and cost-effectively modified for changing needs. The CMS40 system's simple assembly/disassembly supports this concept, allowing reuse of system components during extensions or renovations.

Health and Safety

The Health and Safety at Work Act, Consumer Protection Act, and other legislation mandate that we provide critical safety information regarding the handling, processing, storage, transportation, and disposal of our products. Below are essential considerations specifically for rainscreen cladding installation, with a focus on the CMS40 system.

Handling and Storage

Always wear personal protective equipment (PPE), including gloves, eye protection, hearing protection, and any necessary respiratory protection. This minimises risks from falling objects, sharp edges, and dust generation. Handle CMS40 component packs carefully, ensuring lifting equipment is rated for the pack's weight. Avoid tilting, shocks, or sliding packs, as this can cause product damage. Store packs on a dry, level surface. Choose pallets that closely match the pack size and are strong enough to support the weight. Inspect packaging regularly for damage.

On Site Handling

Use only the designated forklift openings when lifting pallets – never use "side grabs." Ensure packs are secure, especially when being lifted. Do not move opened packs of stacked units around the site; lay units flat instead. When packs are lifted more than 1 metre above ground level, implement a safety cage of suitable dimensions to prevent components from falling. Maintain a safe perimeter around any lifted or moved packs.

Disposal of Packaging

Collect waste materials daily and dispose of them in approved waste disposal skips for transport to an approved disposal site. Burning packaging materials is often prohibited on construction sites. Comply with all site-specific regulations and environmental controls.

Manual Handling

Repetitive handling of any product, including brick slips, can lead to upper limb disorders like muscular strains and sprains. Seek specialist advice to manage these risks for anyone involved in this type of work.

COSHH

Cutting CMS40 brick slips and carrier rails generates dust. Use wet-cutting methods whenever possible to minimise dust, especially respirable silica, which poses serious health risks. Strictly adhere to COSHH (Control of Substances Hazardous to Health) regulations and monitor exposure levels. Dust can irritate the skin and eyes; wear gloves, barrier cream, and eye protection during any cutting operations. CMS40 components are inert and do not generally off-gas harmful vapours. However, it is the customer's responsibility to obtain technical data and ensure compatibility with all other materials used in the rainscreen cladding system.

Cladmate accepts no liability for issues arising from incorrect material combinations. Respirable silica poses a major health hazard. The main effect in humans of inhaling respirable silica dust is silicosis, which also increases the risk of lung cancer. Since there is no safe threshold for silicosis development, minimizing exposure is crucial. The COSHH Regulations set the Workplace Exposure Limit (WEL) for respirable silica at $0.1\text{mg}/\text{m}^3$. Detailed personal monitoring is the only reliable way to determine individual exposure levels during cutting.

Cutting aluminium can also generate flammable dust. Employ wet-cutting equipment whenever possible to drastically reduce dust generation. Dust can also irritate the skin, so wear suitable gloves and barrier cream. Always wear eye protection and ear defenders when mechanically cutting materials.

CMS40 components are manufactured in the UK from naturally inert materials and do not release harmful vapours. Clay products are non-toxic. However, it's the customer's responsibility to obtain technical data and ensure compatibility with all other materials used within the rainscreen cladding system. Cladmate accepts no liability for issues arising from incorrect material combinations.

Important Notes

- **Customer Responsibility:** Customers must inspect all products and packaging before handling or storage. Cladmate is not liable for issues arising from a lack of inspection or from the incorrect use of products.
- **HSE Guidance:** For broader health and safety recommendations in the construction industry, especially regarding brick and clay products, refer to the HSE website (<http://www/hse.gov.uk/>). It is recommended that customers become familiar with the full breadth of HSE guidance around the use of these materials.
- **Disposal:** Cladmate accepts no liability or responsibility for any disposal of unwanted materials or packaging. A copy of our terms and conditions of business is available on request.



CMS40 Warranty

Cladmate offers a durability warranty on CMS40 Brick Slip Cladding Panels, assuming correct installation.

The warranty does not cover the supporting masonry. For warranty information and duration, email Cladmate Technical Services at technical@cladmate.co.uk (include project details).



To enroll our RIBA approved CPD's please scan the QR code below.



MFSLIP[®]

CMS40 Mechanically Fixed Brick Slip Cladding System

**CLADMATE**
Facade Systems

CLADMATE FACADE SYSTEMS LTD.

Head Office :
1 Bedlam Mews
London, SE11 6DF

www.cladmate.co.uk
info@cladmate.co.uk
0 20 3949 8826

